

# The Design, Fabrication and Measurement of Microstrip Filter and Coupler Circuits

By Dana Brady  
CAP Wireless, Inc.

These practical microstrip examples provide a valuable tutorial on the use of many different engineering resources: published references, comprehensive EDA tools, EM analysis and rapid prototyping equipment.

Today's microwave designers rely on many tools to help create effective circuits and systems. They use their libraries of published references, along with powerful EDA design tools and electro-

magnetic (EM) analysis tools, combined with the lessons of their own experience. Their work is verified with the construction and testing of a finished circuit. This article describes two microstrip designs that were developed using different methods, fabricated quickly using a p.c. board milling machine, then measured to determine the accuracy of the design methods.

The example designs are a classic hairpin filter with a bandwidth of 3.7 to 4.2 GHz, and a 1 to 8 GHz directional coupler using the Schiffman sawtooth, or zig-zag, technique to reduce the size. The hairpin filter was designed and simulated using Agilent ADS 1.3 [1], with planar EM analysis using Sonnet Lite [2]. The coupler used a design-rule-based transformation, starting from an existing stepped-line coupler design. Both circuits were fabricated on a Protomat C100HF from LPKF Laser & Electronics [3], with measured results obtained using an HP (Agilent) 8753E network analyzer.

## Design example #1: A 3.7 to 4.2 GHz hairpin filter

This filter was designed for a flat response over the 3.7 to 4.2 GHz band, with low insertion loss and return loss better than 16 dB across the band. The filter's application is

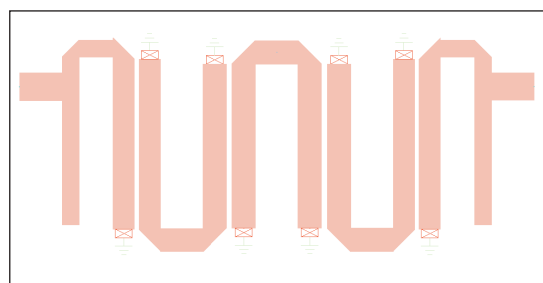

Figure 1 · Layout of the 3.7 to 4.2 GHz hairpin filter, designed with the help of ADS 1.3.

image rejection at the input of a synthesized block downconverter. A classic hairpin design was chosen, since experience has shown that it would meet the performance and size requirements for this design.

The filter was designed using ADS 1.3, with the resulting layout shown in Figure 1. This, of course, is the familiar hairpin configuration. The area occupied by the filter is approximately 500 by 1200 mils (0.5 x 1.2 in.), plus sufficient area beyond the hairpin loops to maintain consistent dielectric properties.

Figure 2 shows the design and optimization setup in ADS. Since this topology has symmetry around the center, it was designed as two sections, connected in a “back-to-back” configuration. With this reduction in the size of the mathematical problem, calculation time is significantly reduced.

The optimization was set up to obtain a minimum 16 dB return loss within a passband of 3.55 to 4.4 GHz, and a minimum stopband attenuation of 28 dB below 3.2 GHz and above 4.7 GHz. The optimization was set up for a frequency range of 3.0 to 5.0 GHz. A wider range is not required to obtain the desired results.

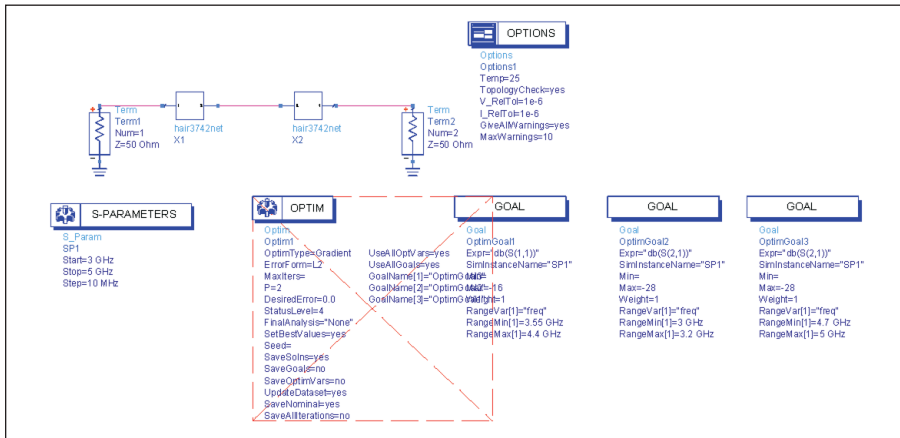

Figure 2 · Optimization setup in ADS. As noted in the text, the filter was simulated as two “mirror image” sections to exploit the filter’s symmetry.

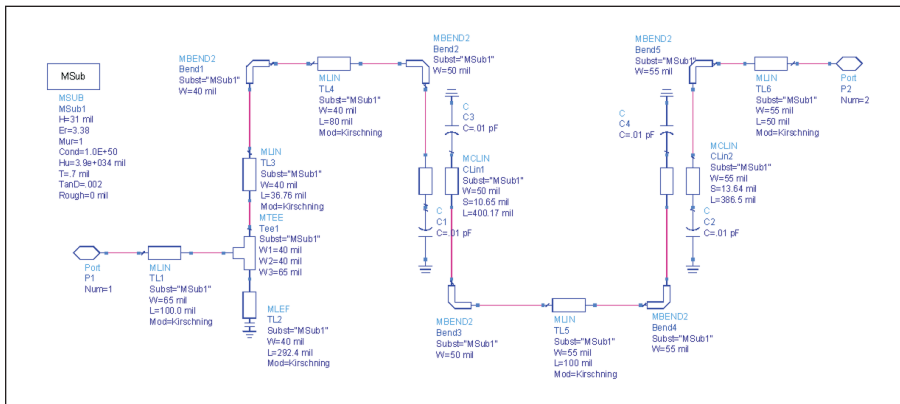

Figure 3 · The ADS simulation definition of the final design. Simulated performance data and filter layout are derived from this data.

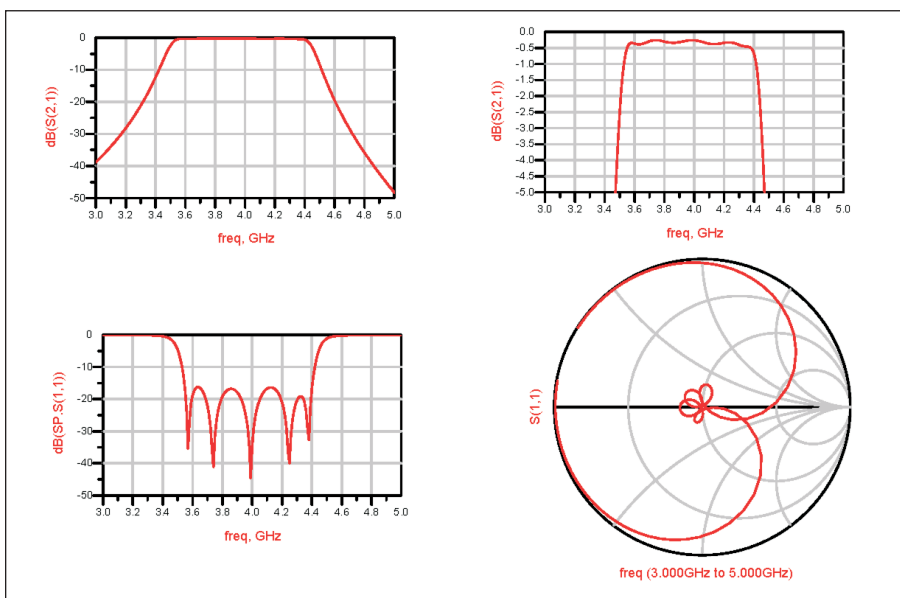

Figure 4 · Simulation results for the filter: (a) overall response, (b) passband response and insertion loss, (c) return loss, and (d) Smith chart impedance

The final ADS design for each “half filter” is shown in Figure 3, including the ports, microstrip lines, tees, bends and stubs. Note the 0.1 pF capacitances at the end of the stubs to account for end effect (fringing capacitance). These are also shown in the layout diagram of Figure 1.

Modeled performance is shown in Figure 4. These plots show the passband, stopband, return loss results of the ADS simulation, along with a Smith chart plot of input/output impedance. These plots show that the ADS model meets the filter’s design criteria.

### EM analysis

A detailed diagram of the filter dimensions is shown in Figure 5. This layout data was used to set up an analysis of the circuit using the free Sonnet Lite planar electromagnetic field solver software from Sonnet Software, Inc.

Figure 6 shows the results of EM analysis. The passband response is slightly narrower than predicted by ADS, but will cover the desired 3.7 to 4.2 GHz band if the performance of the fabricated circuit matches this analysis. Passband flatness is very close to that modeled by ADS. Return loss response is less symmetrical across the passband than the ADS simulation, but it remains at 16 dB or better.

### Fabricating a test filter

To compare the performance of the modeled hairpin filter design with its real-world counterpart, a test filter was fabricated on a typical microwave laminate, using a p.c. board milling machine (LPKF Protomat C100HF—see the sidebar on page 29).

Layout data from ADS (Figure 1) was used to create the necessary driver files for the milling machine. These dimensions were transferred directly from ADS into the LPKF setup software. Figure 7 is the layout for fabrication of the board.

**Measured performance**

After the board was milled to the desired pattern, connectors were attached and the filter was measured using an HP 8753E network analyzer. Figure 8 is the through performance ( $S_{21}$ ) and return loss ( $S_{11}$ ) of the prototype filter. The scale of this plot is 5 dB per division to show the overall passband/stopband performance down to -45 dB.

Figure 9 is the same as Figure 8, but with the passband plot scaled at 1 dB per division to show the passband flatness. The return loss plot remains at 5 dB per division.

The measurements show very good agreement with the models. The passband is slightly narrower than predicted by ADS, but by a smaller

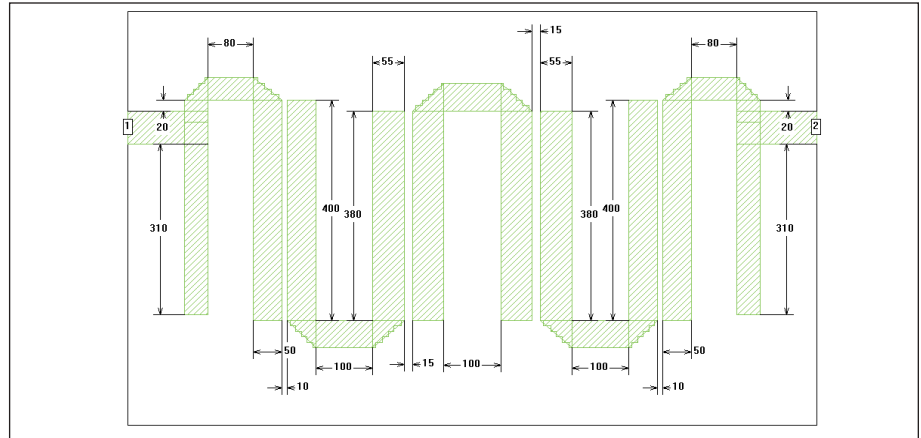

Figure 5 · Detailed dimensions of the hairpin filter.

amount than the Sonnet Lite analysis indicated. All three methods of modeling and measurement were in

agreement on the insertion loss and the flatness of the passband.

Although there are variations in

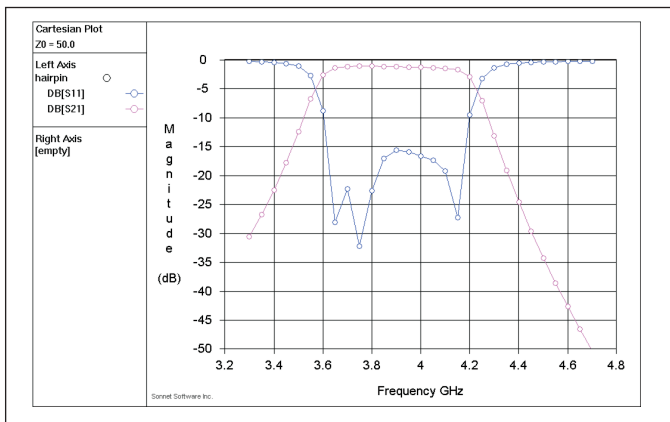

Figure 6 · EM analysis results from Sonnet Lite, which indicates that the response satisfies the design criteria.

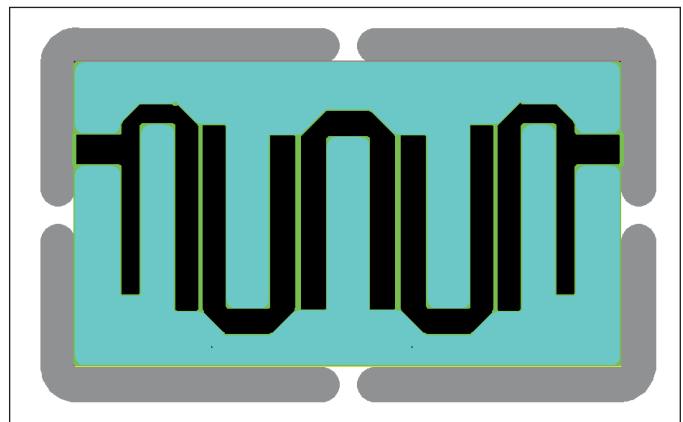

Figure 7 · Circuit board layout for milling with the LPKF machine.

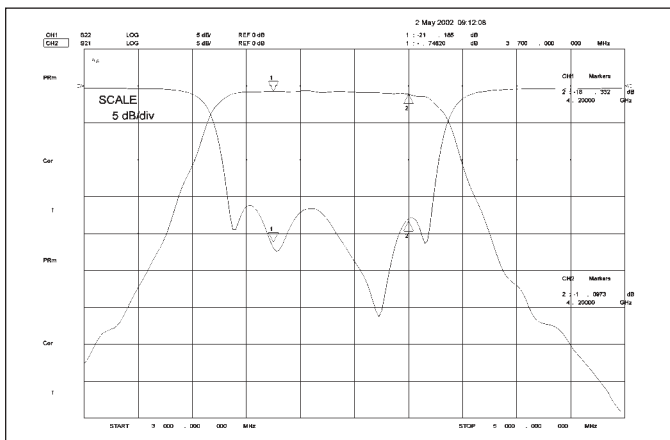

Figure 8 · Passband and return loss measurement of the prototype filter on a milled p.c. board.

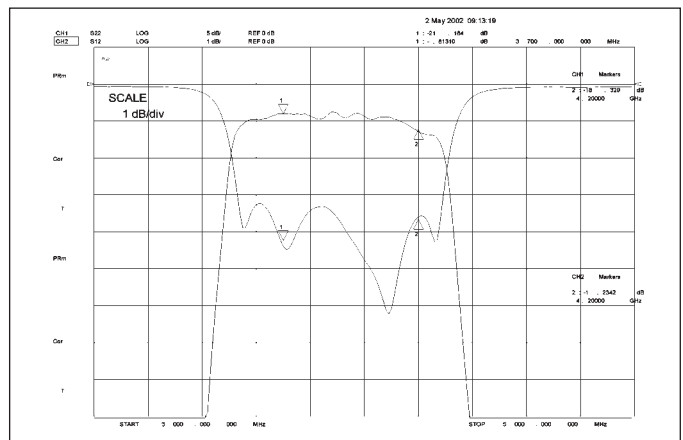

Figure 9 · Same as Figure 8, but 1 dB per division resolution to obtain a detailed passband measurement.

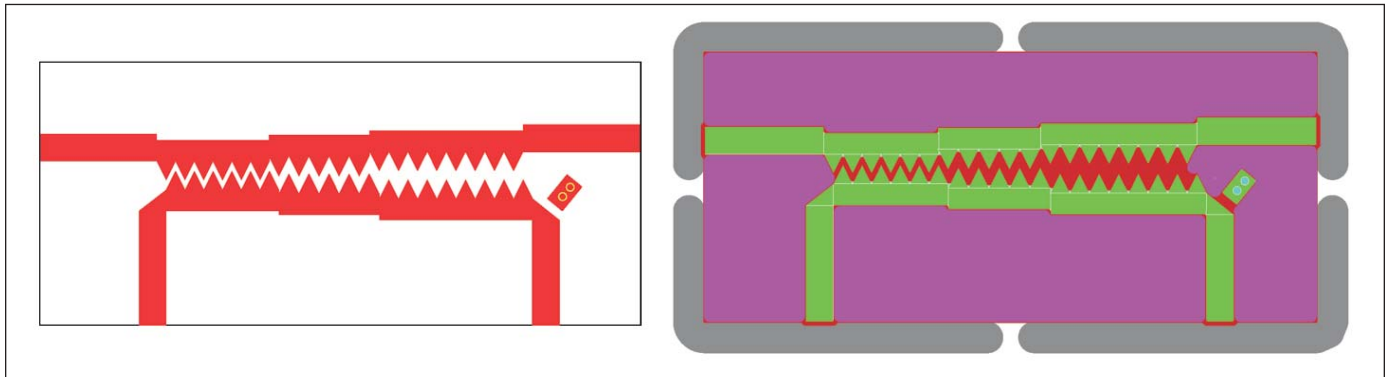

Figure 10 · This basic layout (left) and fabrication template (right) illustrate the technique used for the Schiffman reduced-size directional coupler.

the shape of the return loss plots among the modeled and measured data, each of them maintains the desired 16 dB specification, and clearly shows the expected “humps” of a multi-pole filter response.

### Design example #2: A reduced-size stepped-line directional coupler

The next circuit we’ll examine was developed using an empirical technique. We wanted to investigate a method of reducing the size of microstrip circuits developed by Schiffman, as described by Uysal [4]. This technique uses a sawtooth or zig-zag pattern to reduce the mechanical length required for a given electrical length.

An existing 1 to 8 GHz stepped line coupler, designed in ADS by CAP

Wireless colleague Paul Daughenbaugh, was used as the starting point. This design was translated into a layout for fabrication on the milling machine, similar to the one shown in Figure 10. This figure actually shows a different version of the coupler, but it clearly illustrates the technique.

An empirical method was used to obtain the new coupler layout from the straight-section coupler design, using the following rules:

- *Wide-spaced coupler section*—The total length along the zig-zag path was made equal to the straight line length of this section. This reduced the length of this section by a factor of nearly half. The spacing between straight lines was maintained between the “interlocking” teeth, as measured across the gaps at right angles to their edges.

- *Wide-spaced coupler section*—The spacing between the lines of the third section was calculated at the mid-height of the teeth. At this wide spacing, it was assumed that the fields would couple according to this average spacing, rather than along the edge path of the first section. Also, the length reduction is less in this section. For simplicity, the same length as the original straight line section was used.

- *Center section*—The line spacing and the length reduction of the center section was calculated as the geometric mean of the first and third sections.

This “best guess” approach was necessary because it was not possible to analyze this structure using the available software tools. It is too complicated for analysis with Sonnet

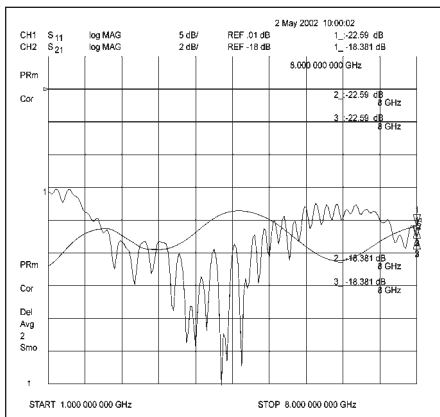

Figure 11 · Coupled port transmission and input port return loss.

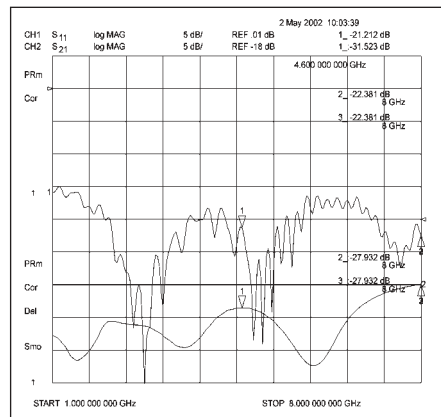

Figure 12 · Reverse coupling and output port return loss.

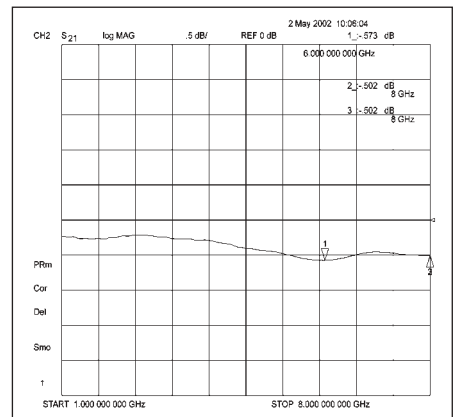

Figure 13 · Insertion loss (vertical scale is 0.5 dB per division).

Lite, and other analysis tools were not available.

### Coupler performance

After fabrication with the LPKF milling machine, the coupler was evaluated for the degree of coupling, directivity across the 1 to 8 GHz band. In Figure 11, the coupled port transmission is the smooth line. The horizontal line at the center of plot is

-18 dB and the grid is 2 dB per division. Coupling is -19 dB  $\pm$ 1.5 dB over the measured frequency range. In the same figure, input return loss is plotted at 5 dB per division, referenced to 0 dB at the second line from the top. Worst case return loss is 16 dB at the lowest frequencies.

Reverse coupling is plotted in Figure 12, along with output port return loss. Both plots are 5 dB per

division. For reverse coupling, the center line is the reference, again at -18 dB, and coupling is -28 dB or better across the band, better than 31 dB at all but the high frequency end. The output port return loss is plotted using the same scale as input return loss in Figure 11, and also shows the same 16 dB worst case performance at 1 GHz.

Directivity (forward coupling

## Using a Milling Machine for p.c. Board Prototyping



The milling equipment used at CAP Wireless is the model Protomat C100HF from LPKF Laser & Electronics. This unit can accommodate a board up to 13.5 x 8 inches (340 x 200 mm). In addition to circuit boards, the unit can mill aluminum or brass mechanical parts or cut copper shielding foils.

The motor operates at variable speeds from 10,000 to 100,000 RPM, software controlled. The typical fine-pitch milling tool for boards like those described in this article is a 10 mil endmill, specified for a diameter variation of  $\pm$ 0.2 mils:

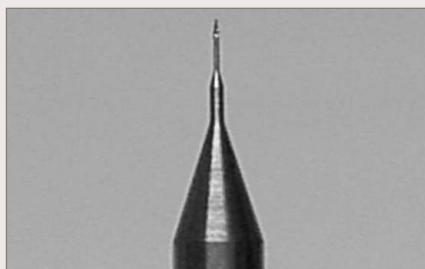

The positioning accuracy of the machine is very important, to maintain the necessary precision for both *x-y* axis dimensions and the depth of penetration. The machine must reliably cut the entire copper cladding layer, while removing a minimal amount of the underlying dielectric material.

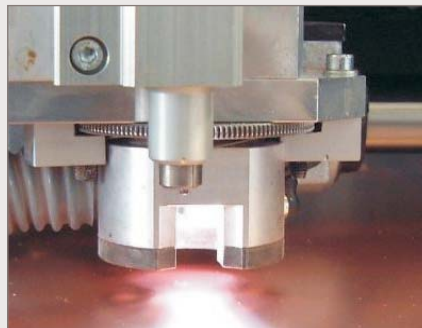

The photo above is a closeup of the milling head. The C100HF uses dynamic *z*-axis positioning with a coaxial working depth limiter to maintain the milling depth. The penetration into the substrate is typically 0.2 mil (5 micron). The *z*-axis movement range is 14 mm (0.55 in.). An air bearing provides accurate, but non-contact surface sensing on soft or flexible boards, and on surface-sensitive materials.

The *x-y* positioning accuracy is less than 0.2 mil (5 micron) at a resolution of 0.3125 mil (7.9 micron). The following electron microscope photos show a milled path at two different magnifications—note the

50 micron and 10 micron scale references at the bottom of the photos.

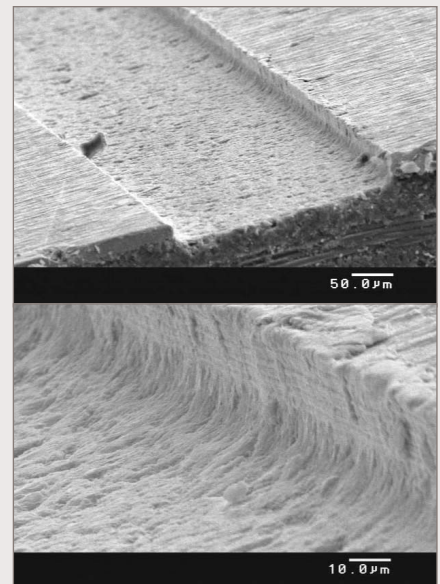

With a travel speed of 40 mm/sec (1.575 in.), both fine-pitch milling and runout of large areas is accomplished efficiently. If necessary, it is possible to build and test several iterations of a board design in a day. In some cases, the unit will be an acceptable alternative to conventional etched p.c. board fabrication for custom designs and small-quantity production.

Readers wishing to find out more about this unit may contact LPKF Laser & Electronics by telephone at 1-800-345-LPKF (1-800-345-5653), by e-mail at [info@lpkfusa.com](mailto:info@lpkfusa.com), or online at [www.lpkfusa.com](http://www.lpkfusa.com)

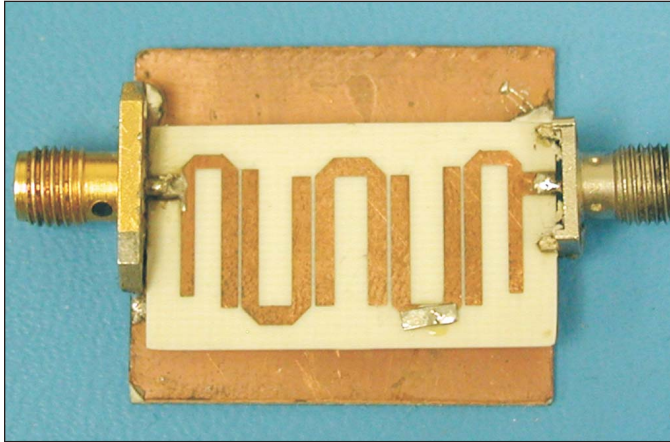

Figure 14 · Photo of the 3.7 to 4.2 GHz hairpin filter prototype board.

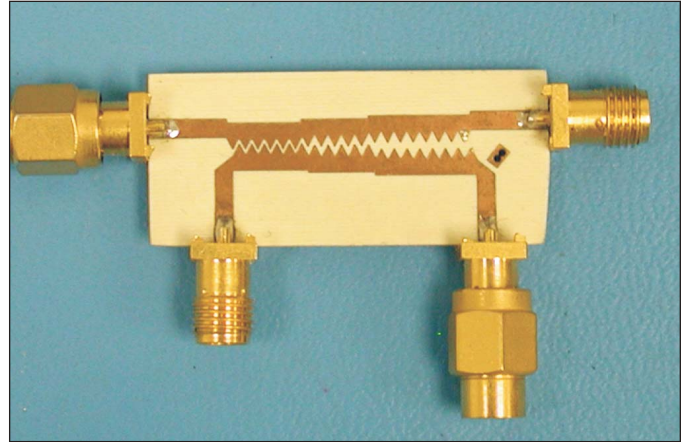

Figure 15 · Photo of the 1 to 8 GHz broadband coupler using the Schiffman, or zig-zag line, technique.

minus reverse coupling) is 10 dB over all but the extreme high end of the band. The design goal was >10 dB, with a target of 12 dB to allow extra margin. This margin was achieved over most of the band, which we consider to be an excellent result for a first iteration.

Figure 13 is insertion loss, which is 0.25 dB at 1 GHz, with a worst case of 0.57 dB at 6 GHz. The variation in insertion loss is just 0.33 dB across the entire 1 to 8 GHz band.

#### Notes on prototyping with a p.c. board milling machine

The ability to quickly fabricate a prototype p.c. board can change the engineering approach to certain designs. For the directional coupler, we were prepared for the possibility that several design iterations would be required to obtain a coupler with the desired performance. With some luck (and educated guesses based on experience), the first attempt resulted in a good coupler.

The photos in Figures 14 and 15 show the milled boards, with connectors attached for measurement. The hairpin filter board in Figure 14 even shows a patch soldered in place to cover a gap in one of the microstrip traces. This was caused by a small error in the layout file that became evident when the board was milled.

The coupler design may yet be modified to improve low-end return loss or flatten the coupling response. These small changes would probably not be considered with conventional fabrication using an outside board shop. Most companies no longer maintain in-house board etching labs, since environmental regulations, particularly in California, add significant cost and complexity to the chemical etching process.

#### Summary

It is hoped that these design examples show how we used many different design resources. To create these filter and coupler circuits, the experience of several engineers was combined with published data, advanced circuit theory simulation, EM analysis and, finally, fabrication and measurement. Each step in the process contributed to the overall design success.

#### References

1. Agilent Technologies, Inc.; information at [www.agilent.com](http://www.agilent.com)
2. Sonnet Software; information at: [www.sonnetusa.com](http://www.sonnetusa.com)

3. LDK Laser & Electronics; information at: [www.lpkfusa.com](http://www.lpkfusa.com)
4. Sener Uysal, *Nonuniform Line Microstrip Directional Couplers and Filters*, Artech House, 1993.

#### Additional Design References

5. G. Matthei, L. Young, E.M.T. Jones, *Microwave Filters, Impedance-Matching Networks, and Coupling Structures*, Artech House, ISBN 0-89006-099-1.
6. J.A.G. Mahlerbe, *Microwave Transmission Line Filters*, Artech House, ISBN 0-89006-063-0.

#### About the Author

Dana Brady is Senior Engineer at CAP Wireless, Camarillo, CA. Previously, he has held Senior Engineer positions at California Amplifier, Armatek and Amplica, and the Chief Scientist position at JCA Technology. He attended California Polytechnic State University and has experience in the design of many RF and microwave circuits and systems, including various microprocessor-controlled microwave subsystems. He can be reached by e-mail at: [danab@capwireless.com](mailto:danab@capwireless.com)

To submit a technical article for our consideration, simply e-mail a brief description to: [editor@highfrequencyelectronics.com](mailto:editor@highfrequencyelectronics.com) Author guidelines can be found on our web site: [www.highfrequencyelectronics.com](http://www.highfrequencyelectronics.com)