

A 2.6 GHz Microstrip Hairpin Filter Design Using CAD and EDA Tools

Design software and mechanical prototyping combine to create a practical filter

By **Luigi Greco**, Ansoft Corporation
and **Stephan Schmidt**, LPKF Laser and Electronics

For companies to compete in today's wireless communications industry, CAD/EDA tools must be an integral part of the wireless product design cycle. These tools are essential in addressing design engineers' concerns with reduced design cycles and time-to-market. CAD/EDA tools must possess the characteristics of simulation accuracy and ease-of-use, which allow design engineers to achieve maximum productivity.

This article discusses the design of a 2.6 GHz microstrip hairpin bandpass filter using the Harmonica circuit-level simulator in Ansoft Corporation's Serenade® Design Environment. The design was exported to Ansoft's Ensemble (2.5D planar electromagnetic simulator) and to LPKF's prototyping applications via Serenade's layout tool, S2A. The main purpose of this design exercise is to validate the results from Serenade to those from Ensemble and measured data.

Table 1 summarizes the CAD/EDA tools used in this design exercise. Note that all the tools used are for the PC.

Filter design

A four-section microstrip hairpin filter topology was used to provide a bandpass response centered at 2.6 GHz with a 3 dB bandwidth of approximately 280 MHz. The initial design was entered by schematic cap-

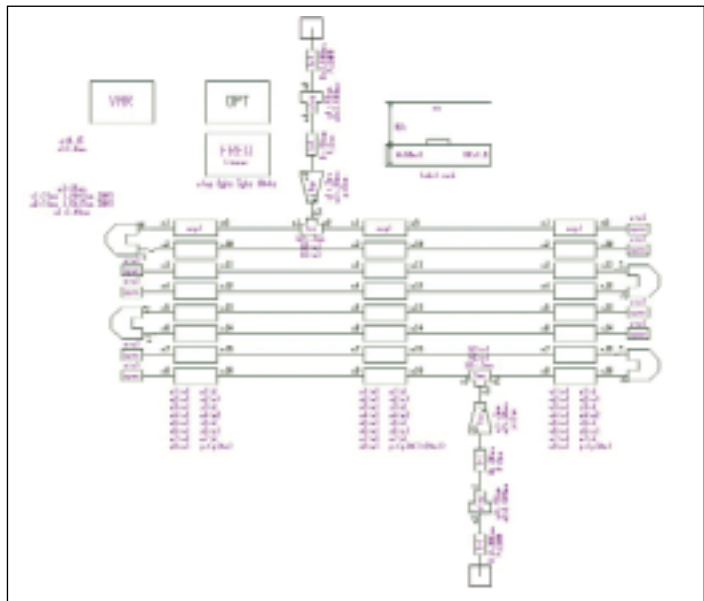

▲ Figure 1. Schematic of the microstrip hairpin filter in Serenade.

ture in the Serenade desktop, shown in Figure 1, using Harmonica's microstrip distributed elements library.

Product	Function
Ansoft Serenade Design Environment	Schematic capture of the structure and simulate with the Harmonica circuit level simulator
Ansoft S2A	Serenade's layout tool
Ansoft Ensemble	2.5D planar electromagnetic simulator
LPKF ProtoMat 95s	PCB prototyping machine
LPKF CircuitCAM	CAD/CAM software to prepare the PCB
LPKF BoardMaster 2.8	Software used to control the ProtoMat 95s

▲ Table 1. CAD/EDA tools used in the filter design.

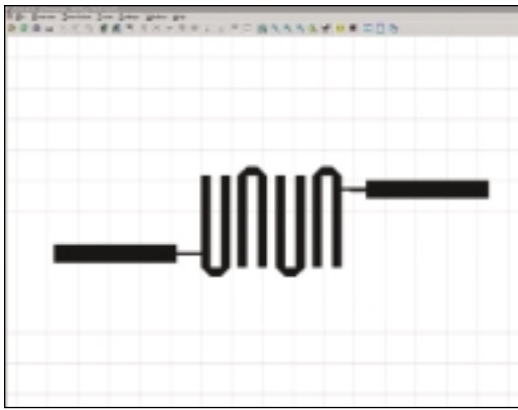

▲ Figure 2. Layout file for the filter generated in Serenade layout.

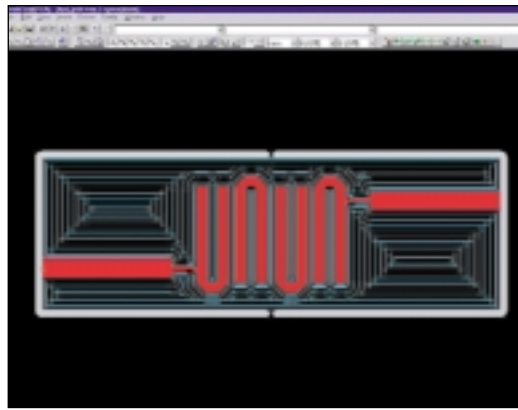

▲ Figure 3. Cutting tool paths created in LPKF's CircuitCAM program for the filter.

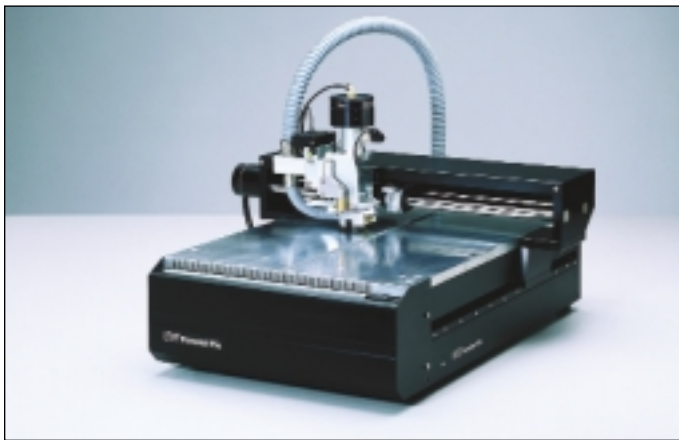

▲ Figure 4. The LPKF ProtoMat® 95s cuts the circuit board direct from CAD data.

Substrate Thickness	60mils (1.524mm)
ϵ_r	$4.5 \pm 0.045 @ 10 \text{ GHz}$
Metallization	1oz Cu (1.4 mil/0.036 mm)
Tan δ	0.002

▲ Table 2. Rogers TMM-4 substrate specifications.

One of the distinguishing features of Harmonica's distributed library models is the multiple coupled line element (MCPL), used in the coupling sections of the hairpin filter. The MCPL element uses a full-wave spectral domain algorithm where the electrical characteristics of up to 20 coupled lines of any combination of widths and spacings can be accurately simulated over a given frequency range. As shown in Figure 1, the MCPL elements are the three sections of eight coupled lines that make up the straight segments in the hairpin filter.

The folds in the hairpin are represented as subcircuits ("U-turn" symbols) consisting of a transmission line and a mitered bend on both sides. Because no en-

sure cover was specified for the filter, radiation effects will be taken into account in the simulation in both Harmonica and Ensemble. The substrate defined in the schematic is that of Rogers TMM-4. Specifications are listed in Table 2.

The filter design dimensions were optimized to meet the specifications in the passband. Because the MCPL elements can have any combination of widths and spacings, the symmetry of the filter was preserved by optimizing variables that represent the symmetrically opposed widths and spacings.

Filter construction

After the filter has been optimized in Harmonica, the topology is ready for layout. The S2A layout tool is launched from the Serenade desktop menu to create an auto-generated layout (see Figure 2).

Next, a DXF file of the layout is created in S2A so that it can be imported to the LPKF CircuitCAM application and subsequently prepared for PCB machining controlled via the LPKF BoardMaster application. The CircuitCAM application is used to check and edit a layout as well as create isolation channels between conductor traces. This is shown in Figure 3. The final layout is sent to the LPKF ProtoMat 95s system for machining.

In addition to exporting a DXF file, S2A was used to export the Ansoft Neutral File Set (ANFS) used to create the filter design project for Ensemble. Figure 4 shows a false-color image snapshot of the magnitude of the RF currents at 2.6 GHz in the filter obtained after simulation in Ensemble.

Filter measurement

After the filter was fabricated, SMA connectors were soldered to the filter. Figure 5 shows the final prototype used in the measurement. The insertion and return losses were measured using the HP 8510B network analyzer. Serenade has the capability to read and save *S*-parameters directly from a wide range of network analyzers via a GPIB/HPIB interface.

Data comparison

Figure 6 show the comparisons between Harmonica, Ensemble and measured data for insertion and return losses. For a first-pass prototype, the data are in good agreement. Table 3 summarizes the 3 dB points, bandwidth and center frequency for the three data sets.

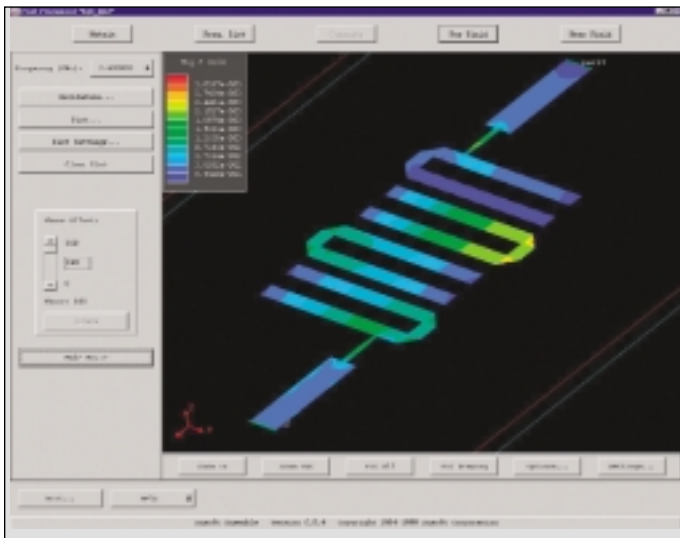

▲ Figure 5. Ensemble model of the filter created, exported via Serenade layout.

Conclusions

The design and validation of a 2.6 GHz microstrip hairpin filter has been discussed. Simulated data from Harmonica in Ansoft's Serenade Design Environment was compared with Ansoft's Ensemble 2.5D planar electromagnetic simulator and prototype measurement. The filter layout created by the S2A Layout tool was used to export a DXF file to LPKF's CircuitCAM and BoardMaster applications for fabrication on the ProtoMat 95s. The return and insertion losses from the Harmonica circuit simulator were compared against Ensemble and measurement and were all found to be in good agreement. ■

Acknowledgments

The authors gratefully acknowledge the assistance of Michael Ford (LPKF), Gregg Albrecht (Motorola), Aron Kain and Rao Gudimetla (Ansoft).

Author information

Luigi Greco received a BS in Physics from Fordham University in 1987, an MS in Physics from the Colorado School of Mines in 1990 and a Ph.D. in Materials Science from the Colorado School of Mines in 1994. At the Colorado School of Mines, he worked in the field of materials research on high-temperature superconduc-



▲ Figure 6. Photo of the completed filter.

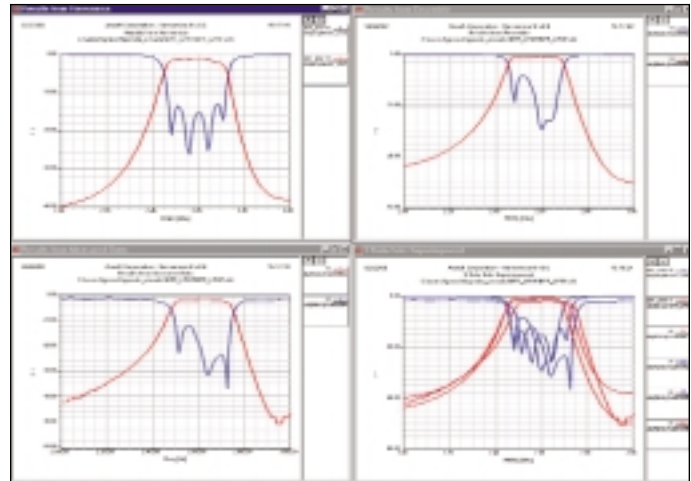

▲ Figure 7. Comparison of the insertion and return losses for the hairpin filter. Clockwise from the upper left trace the results are from Harmonica, Ensemble, measured data and a superposition of all three data sets.

tors and aluminum gallium arsenide compounds. From 1994 to 1997, he worked in RF component design and manufacture at MicroSignals, Inc., and performed computer modeling of high-reflectivity multilayer gallium arsenide mirrors for ring-laser gyroscopes at Fordham University. He joined Ansoft Corporation in 1997 as a Senior Applications Engineer for the Serenade Design Environment circuit and system simulators, working with customers on wireless circuit and system designs. He is also involved in the creation of product application notes and the development of new circuit and system simulation models for Serenade.

Stephan Schmidt received a degree in Electronic Test and Measurement from the Technikerschule in Hannover, Germany, in 1994. He joined LPKF Laser & Electronics at the company's headquarters in Garbsen, Germany, in 1984. In 1994, he began working in inter-

	Lower 3 dB Cutoff (GHz)	Upper 3 dB Cutoff (GHz)	3 dB Bandwidth (MHz)	Center Frequency (GHz)
Harmonica	2.450	2.730	280	2.590
Ensemble	2.450	2.700	250	2.575
Measured	2.480	2.760	280	2.620

▲ Table 3. Summary of the filter frequency characteristics between the three data sets. The center frequency data are all within $\pm 1\%$ of 2.600 GHz.

national technical sales of rapid PCB prototyping systems with a focus on RF and microwave applications. Since 1999, he has been general manager of LPKF Laser & Electronics North America in Wilsonville, OR.